

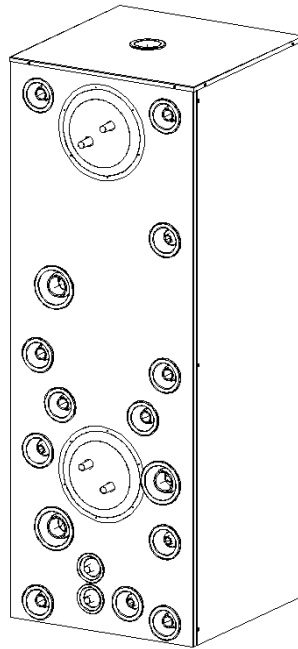

# ULTRASTORE 500 THERMAL STORAGE TANK



## INSTALLATION & USER MANUAL

**NORTHMAN GROUP / JASPI UK**

Web [www.jaspi.uk](http://www.jaspi.uk)  
Email [info@jaspi.uk](mailto:info@jaspi.uk)  
Phone 01392 247343

## **INDEX**

<b>WORKING PRINCIPLE</b>	<b>3</b>
<b>TRANSPORT &amp; HANDLING</b>	<b>4</b>
<b>POSITIONING</b>	<b>4</b>
<b>TECHNICAL DETAILS &amp; MEASUREMENTS</b>	<b>5</b>
INDIRECT COILS	6
<b>GENERAL INSTALLATION ADVICE</b>	<b>6</b>
ELECTRIC IMMERSION HEATERS	6
<b>PIPEWORK</b>	<b>6</b>
Example 1 Air source heat pump connection	7
Example 2 Ground source heat pump connection	7
Example 3 Boiler connection	8
Example 4 Solar thermal connection	8
Example 5 Domestic hot water connection	9
<b>EVERYDAY USE</b>	<b>9</b>
<b>SERVICING</b>	<b>9</b>
<b>FAULT FINDER</b>	<b>9</b>
<b>WARRANTY</b>	<b>10</b>
<b>RECYCLING</b>	<b>10</b>
<b>INSTALLATION CERTIFICATE</b>	<b>11</b>

## WORKING PRINCIPLE

JASPI ULTRASTORE 500 Thermal storage tank can be used in all water-based heating systems. This includes Air and Ground source heat pumps, Biomass boilers, Oil / Gas boilers, Solar thermal and photovoltaic panels. Ultrastore 500 has been designed for easy installation with compact size and uncompromising energy efficiency.

Ultrastore 500 is a Hybrid system where the total volume of water is divided into two main sections. An internal baffle plate is positioned so that the total volume of 500 Litres is allocated to 200 L and 300 L sections. This baffle has a flow-through opening to allow the necessary heat flow between the tank sections.

The lower 200 Litre section is for the heating (radiators & Underfloor heating) buffer. This section also includes the indirect solar coil and the domestic hot water pre-heating coil.

The upper 300 Litre section is reserved for domestic hot water main coil. This section of the tank is normally the warmest point of the system. Normally the heating flow from the boiler(s) or heat pumps is connected to this upper section.

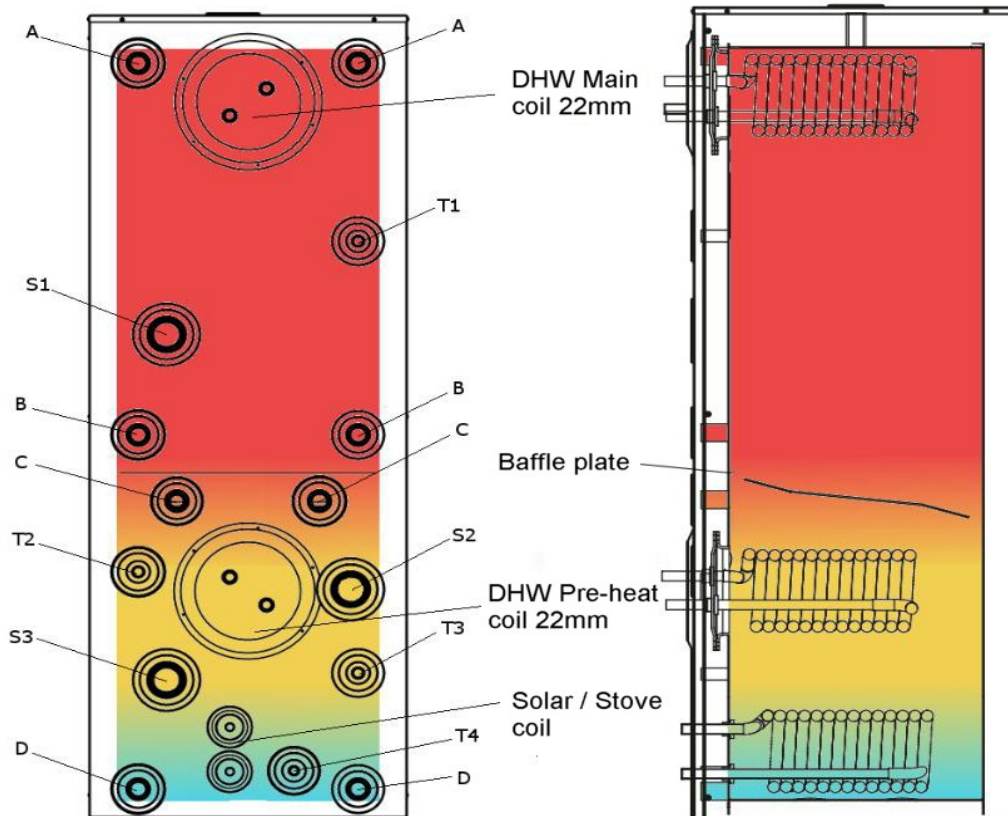

JASPI ULTRASTORE 500

To ensure the availability of domestic hot water we recommend the installation of a back-up heater. Normally this is an electric immersion heater but can also be an oil / gas boiler, boiler stove etc.

This is particularly important if the main heat source is a heat pump which typically produce lower temperatures.

If the store is connected to solar thermal, this is normally sufficient for domestic hot water use during the summer but again a back-up heating is strongly recommended.

Ultrastore 500 can be fitted with up to three immersion heaters (3 - 6kW each).

Above picture shows the heat layering inside the thermal store. The baffle plate allows the highest heat to stay in the upper part of the tank for domestic hot use whilst keeping the solar / stove coil as cool as possible for better thermal transfer efficiency.

### Couplings:

- A: Heat input from the boiler(s)
- B: Heating out (Radiators)
- C: Heating out (underfloor heating or lower temperature radiators)
- D: Heating return

- S1: Immersion heater (priority to domestic hot water)
- S2: Immersion heater (heating and domestic hot water)
- S3: Immersion heater (heating)

More detailed coupling instructions in the example drawings.

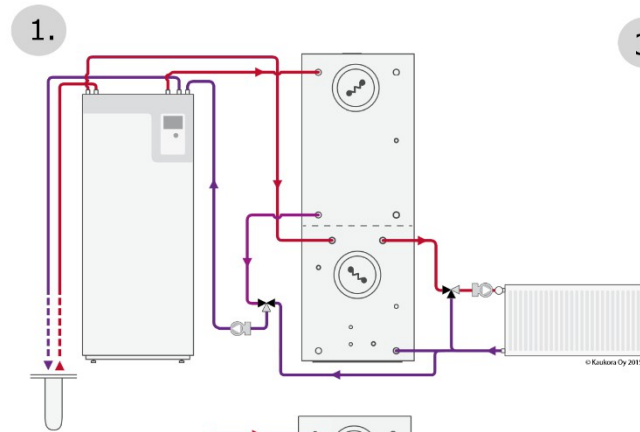

1. Ultrastore 500 with Ground Source Heat Pump  
2. Ultrastore 500 with Air Source Heat Pump

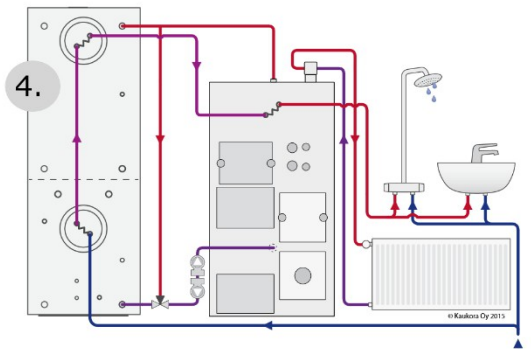
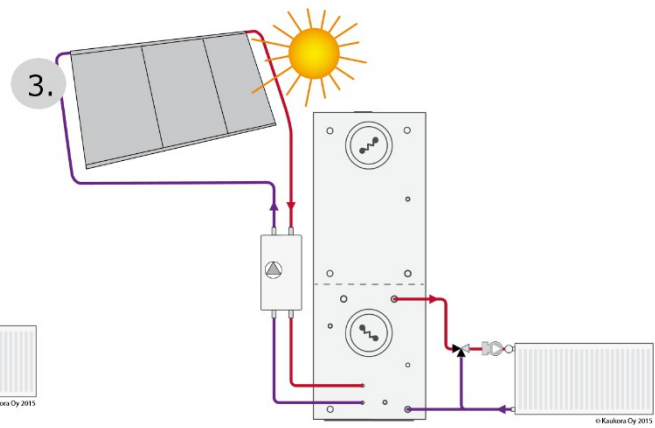
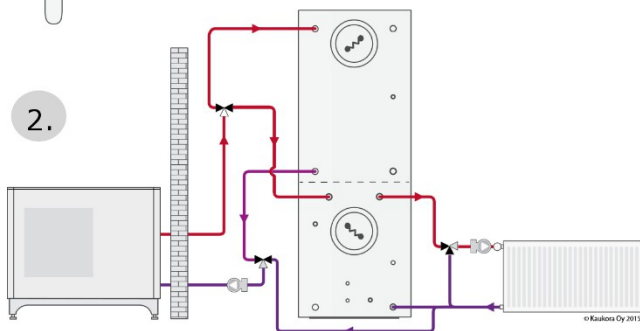

3. Ultrastore 500 Solar Thermal Connection  
4. Ultrastore 500 with Jaspi Multienergy Boiler

Ultrastore 500 is fitted with three coils as standard. Two coils are designed to work with domestic hot water which is heated up twice, first through the pre-heating coil which is then connected to the DHW main coil. This unique arrangement reduces the heat loss (always present in the heat exchangers) to the minimum which in turn allows lower thermal store temperature to be used. As the lower store temperature reduces heat demand from the boiler(s), there is a significant saving in running costs. DHW coils can run on mains water pressure up to 10 bar.

The third coil (lowest in the store) is for Solar thermal or wood stoves up to 20kW. Larger stoves are recommended to be connected directly to the store, not through the coil.

This is to ensure the higher flow rates and lower return temperatures often required by the larger heaters.

In some cases, you can also connect a heat pump to this coil, however it is not generally recommended as the return temperature is higher than with the direct store connection.

## TRANSPORT AND HANDLING

This thermal store is designed to be transported and installed upright.

Laying the store on it's side will damage the outer casing and will invalidate the warranty.

We test all our thermal stores with water before the dispatch so there can be some residual water inside the store. please note that when tilting the store, some of this remaining water can come out from the open ports and can soil any delicate surface like carpets.

Do not strap down the store with excessive force or without surface protection as the paint on the outer casing can get damaged.

## POSITIONING

Jaspi Ultrastore 500 can be connected to any heat source using water as a heat transfer medium.

It is recommended to position the store close to the heat sources to minimise the pipe runs thus improving the energy efficiency.

Due to the weight of the full system, this thermal store is recommended to be positioned on the ground floor with a solid base.

Most suitable base for the store is concrete or stone, if the floor is wood on timber joists, it is very important to ensure the floor can take the weight and if in doubt, strengthen the floor and use a metal or higher density wood board to spread the weight evenly.

If the store have to be placed on the upper floors of the building, the installer must ensure that the floor is strong enough to carry the weight of a full system, including the empty weight of the store. This could mount up to 900kg with the pipework connected.

If in doubt, seek the advice of an structural engineer.

No matter where the store is located, there is always a chance of an accidental water leak from the store, couplings or the pipes connected to it.

Most often this happens when the store is installed or other work is carried out on it later on.

Always keep this in mind and make suitable arrangements to protect your property from a possible leak.

## TECHNICAL SPECIFICATIONS

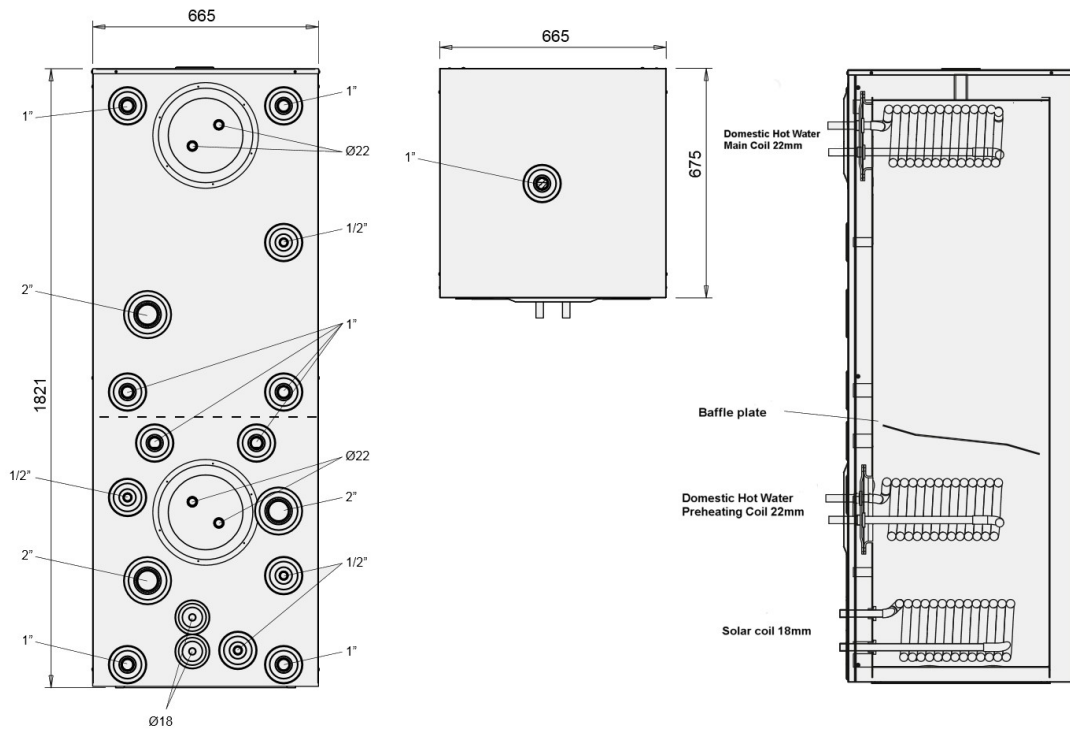

### 1 Dimensions & coupling sizes

Height: 1821mm  
Width: 665mm  
Depth: 675mm  
Weight (empty): 190 kg  
Maximum operating pressure: 3 bar  
Maximum operating temperature: 110°C

## DOMESTIC HOT WATER COILS

Ultrastore 500 has two pre-installed domestic hot water coils.  
They are made of high grade copper alloy with heat spread surface corrugation.  
Length of each coil is 10 Metres, maximum operating pressure 10bar.

Coil type	Flow (l/min)	Power (kW)	Temperature Reference (°C)
LK 2	25	78	80 / 5-50

Liquid volume 3.1 Litres / Coil.  
Total heat transfer area 5.1m<sup>2</sup>

## GENERAL FITTING INSTRUCTIONS

Ultrastore 500 must be fitted on a solid floor and always installed upright. It requires a minimum space of 665 mm x 675 mm.  
Always leave sufficient room for the connected pipework and possible immersion heaters.  
All the connections are in the front and top of the unit.

In general, all the 1" and 2" couplings can be used for the boiler and radiator / UFH connections.  
Maximum recommended pipe size is 32mm.  
Smaller, ½" couplings can also be used for the heating but are most often reserved for the thermostats. If any of the ½" couplings are used for the heating flow / return, the maximum pipe size these is 15mm.

Please note that any coupling above the baffle plate will operate on the higher temperature than the ones below it.  
Therefore, it is recommended that the heating flows are connected above the baffle plate and returns below it.  
However, if a lower temperature flow is needed as for example for a small underfloor heating circuit, this flow can also be connected to a coupling below the baffle plate.

This thermal store must be fitted with a 2.5 or 3 bar pressure relief valve and the functioning of this valve must be checked annually.  
The store must also be fitted with an air relief valve and a drainage point.

The recommended expansion vessel size is 50 litres, vessel pre-pressure 1.8 - 2.2 bar.

## IMMERSION HEATERS

Any electrical connections must only be made by a qualified electrician.

Ultrastore 500 can be fitted with three immersion heaters that have a 2" coupling.  
Two immersion couplings are below the baffle plate and are most often used for night time or cheaper tariff (solar panels) electricity supply.  
The third immersion coupling is above the baffle plate and is used for domestic hot water boost when needed.

Always make sure the thermal store is full of water before testing or using the immersion heaters.  
If the immersion heater runs dry, it will get damaged and void the warranty.

## NOTE

Please note that the Ultrastore 500 can be connected in multiple ways and the examples in this manual are for guidance only.  
They are a good starting point and a reference for the installers but by no means the only correct way to install the system.  
We have a good library of drawings available on download, please refer to these as well if ever in doubt how to install this thermal store.

If ever in doubt, please consult your heating engineer or contact us as we will provide a free telephone support for any items sold.

## Example of a heat pump & radiator coupling

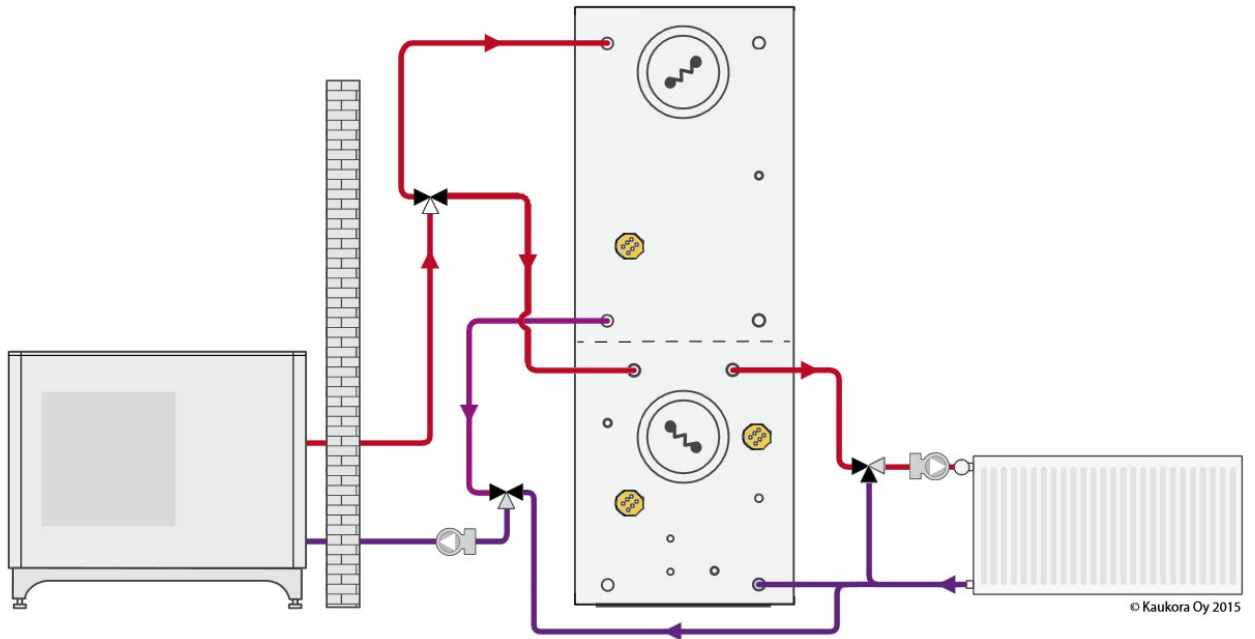

Example uses a Jämä Moon air source heat pump

## Ground source heat pump connection

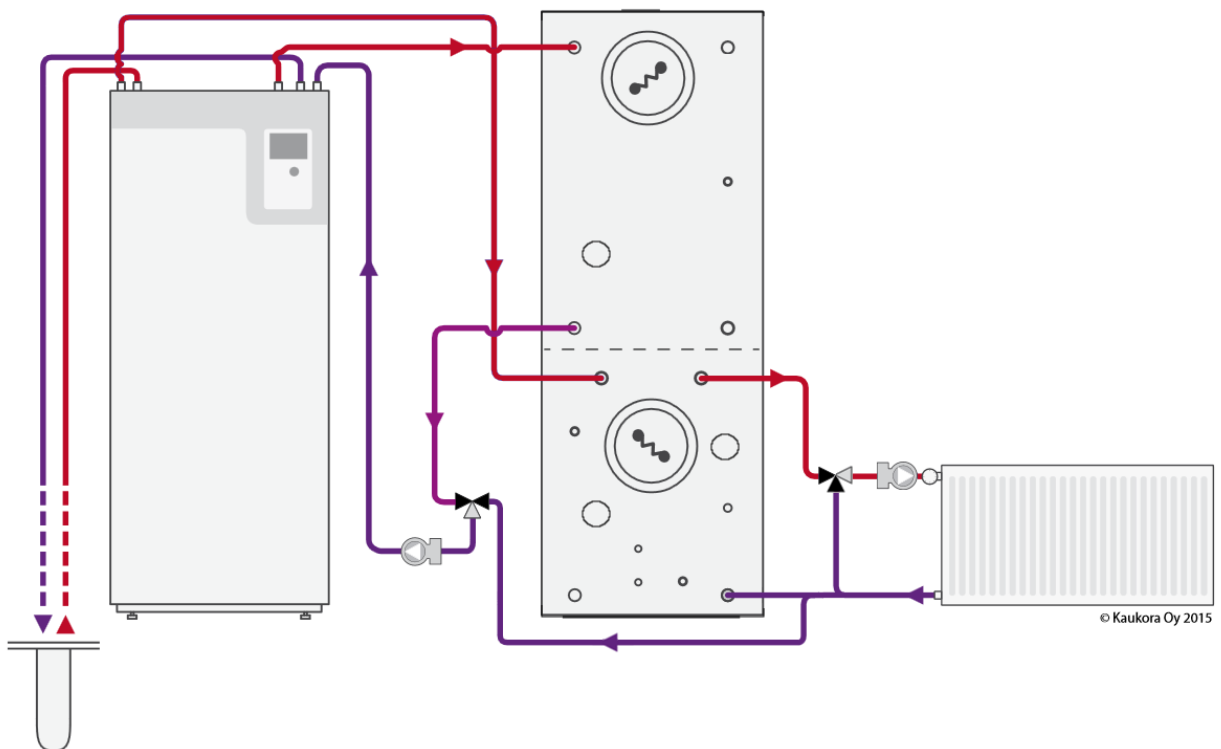

**Example of a Jaspi multi-energy boiler connection**

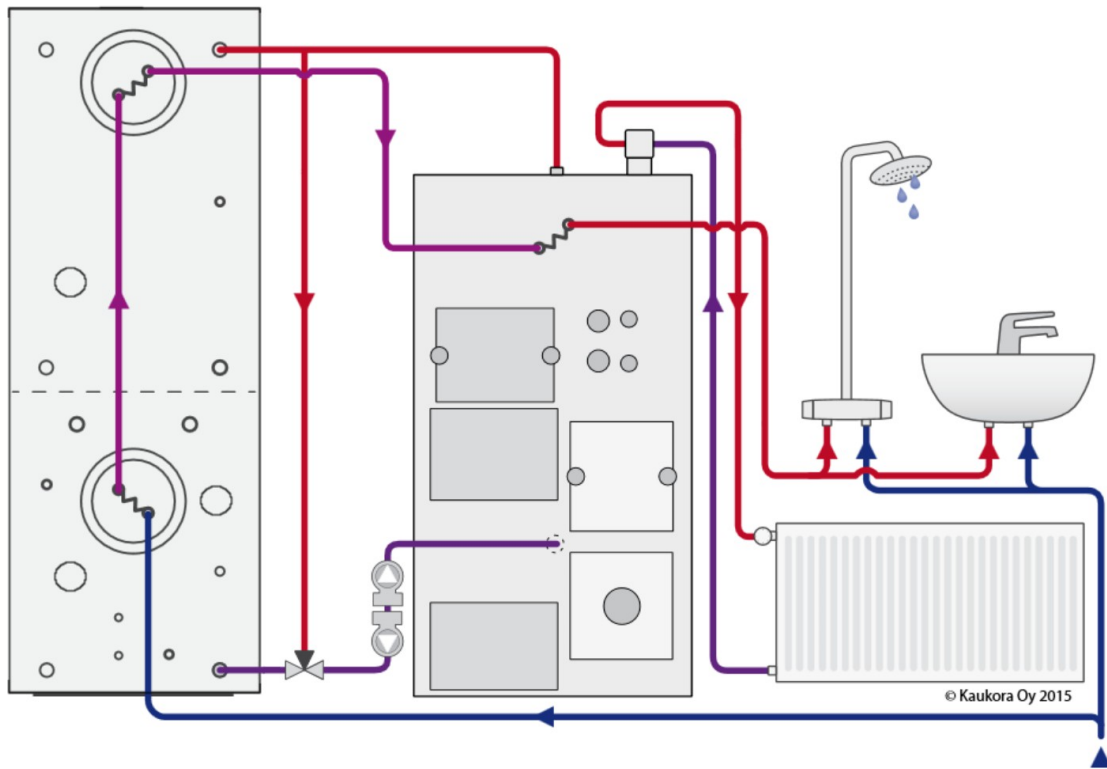

**Thermal solar panel & radiator connection**

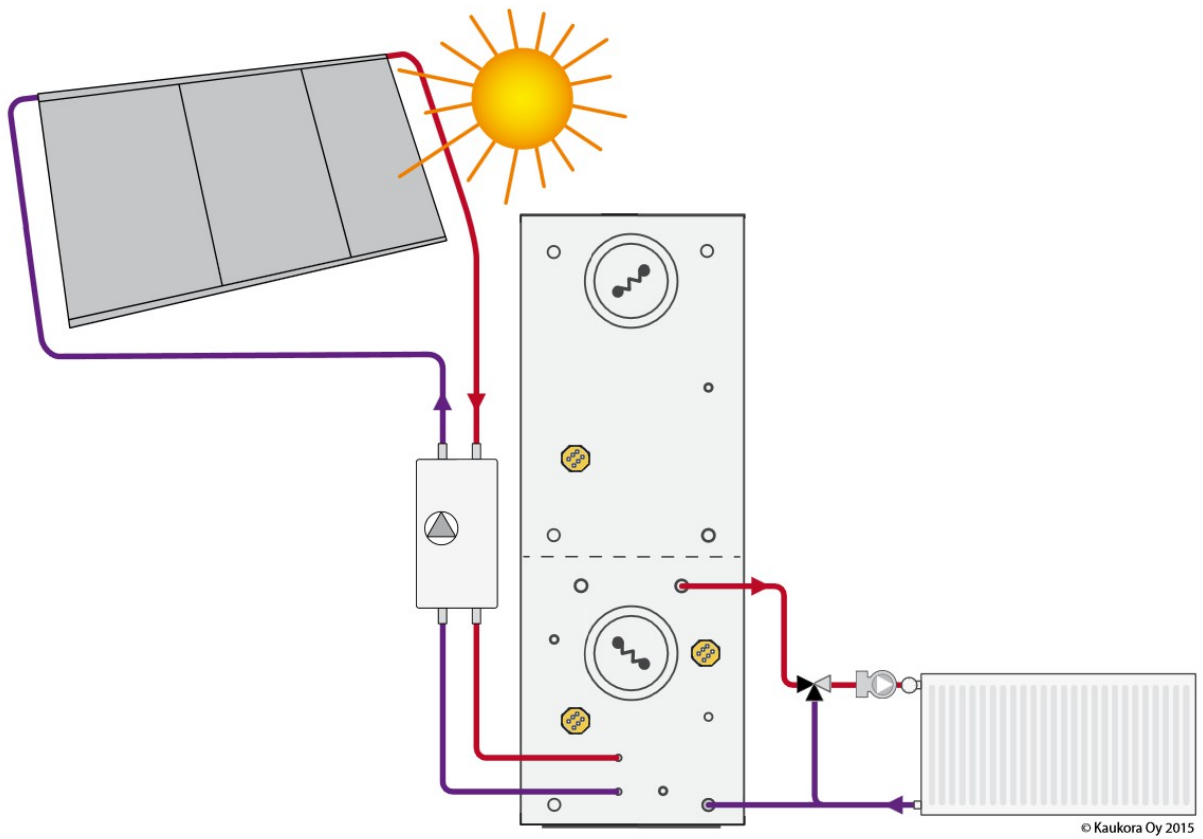



## Domestic Hot Water connection

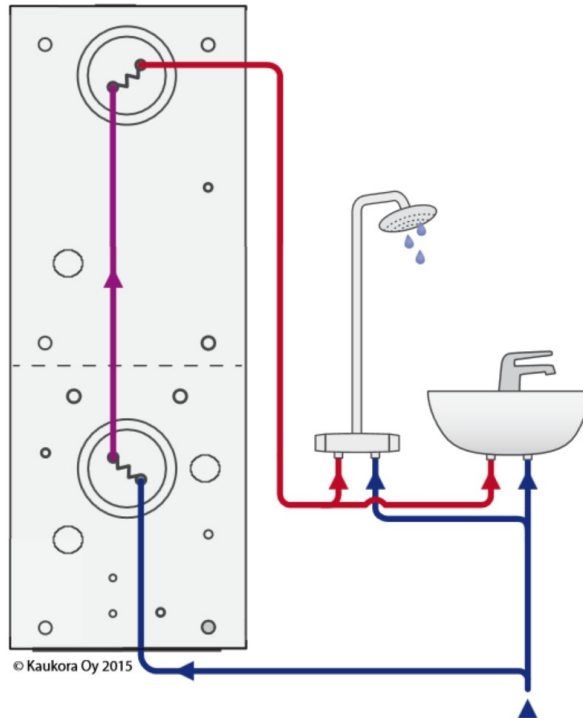

Please note - A DHW circuit must have all the required safety devices fitted, including a pressure relief and non-return valves.

## COMMISSIONING AND USE

Before the system is first used, the installer must ensure that the store is full of water with no visible leaks.

A pressure test up to 3 bar is recommended.

All the connected safety devices, including the pressure relief valves, air release valves and expansion vessel(s) must be inspected and tested annually.

## SERVICE

Ultrastore 500 itself does not require regular service.

It is however recommended to check visually for any leaks on the pipes and their couplings at least once a year.

The functioning of the external pressure relief valves and other connected safety devices must be checked annually.

Any leaks must be rectified as soon as possible to avoid the loss of water in the system.

If the system runs short of water, this can damage the immersion heaters and the circulation pumps.

If there has been a leak in a system and the store has been retopped with fresh water, it is recommended to add an appropriate amount of CH additive fluid into the system as well.

To remove the domestic hot water coils, first remove the round cover. Then cut the insulation with a knife (don't use power tools) to reveal the flange bolts. remove the bolts, leaving the lowest one to the last and pull out the coil.

Be careful not to damage the flange seal as this normally can be re-used.

To remove the solar coil, first remove the lower DHW coil, then open solar coil flange nuts (under the cover & insulation) and push the solar coil into the tank. You can now remove the solar coil from the DHW coil opening.

Refitting is a reverse of the above.

## FAULT FINDING

- Not enough domestic hot water.

Higher store temperature produces more domestic hot water but for example heat pumps can have a fairly low maximum flow temperature.

In this case, it could be necessary to use an extra heat source, for example an immersion heater, to boost up the temperature on the upper part of the Ultrastore. In general it is a good idea to use more than one heat source with any thermal store.

- Drip from the pressure relief valve(s).

Your installation should have at least two pressure relief valves; One for the domestic hot water and another for the thermal store. In some cases, when the thermal store is installed as open-vented, the second pressure relief valve has not been fitted.

Domestic hot water side must always have this valve.

If the domestic hot water pressure relief valve drips occasionally, this is not a fault but the valve is releasing the excess pressure caused by the heat expansion.

Density of the water is at it's greatest at +4°C. If the water gets colder or warmer than this, it's volume will increase.

If the water warms up from +4°C to +80°C, the volume increases by 0.0290.

So one litre of water at +4°C will become 1.0290 Litres at +80°C.

Therefore the volume of water in your domestic hot water system will increase and this extra water will drip out from the pressure relief valve.

If however your domestic hot water system is fitted with an expansion vessel, then there should be no dripping from the valve.

The second pressure relief valve (Max. 3bar) is to protect the thermal store and your heating system from excess pressure.

This valve should not drip regularly. If it does, it is a sign of a problem in the system, often in the expansion vessel, and should be rectified without a delay.

If ignored, the system will start running dry which eventually will damage the pumps and immersion heaters.

A normal heating system pressure is around 1-1.5 bar (excluding the open vented systems) and if you notice that this pressure is zero, it is time to check the system for any leaks.

## **WARRANTY**

Ultrastore 500 comes with a 2 year warranty. Accessories including the immersion heaters are quaranteed for 1 year.

Guarantee does not cover installation issues, lack / errors in maintenance or user errors.

## **RECYCLING**

This product has a long expected useable life. When removed from service, it can often be used again but if damaged, it must be recycled according to the local rules and regulations.

Contact your local authority or metal recycles for further advice.



