

Thermal store for all heating systems



■ Ultrastore 500

Can be used with all heating systems and is optimised for renewable energy sources including Heat Pumps, Solar thermal, Solar PV and smaller Biomass stoves and boilers.

■ Internal Baffle Plate

for improved thermal layering. The baffle plate will keep the hot flow from the boiler / heat pump separate from the cold return lines for maximum DHW availability.

■ 3 Indirect coils as standard

2 Domestic Hot Water coils + 1 Solar coil.

■ Size Optimised Design

Ultrastore 500 has been designed to fit through standard UK doors and the low overall height makes positioning easy.

■ Ultra low heat loss

Unique Heat Moulded high-density closed cell polyurethane insulation for best in class thermal efficiency.

■ Multiple connections

for complete connectivity. Connect several heat sources and heating circuits through new "Leak detect" couplings.

JASPI ULTRASTORE 500

The design principle behind the new Ultra range is uncompromising thermal efficiency.

Automated production where every unit is wet- and pressure tested brings unrivalled quality with low price point.

Expect decades of reliable service at the heart of your heating system.

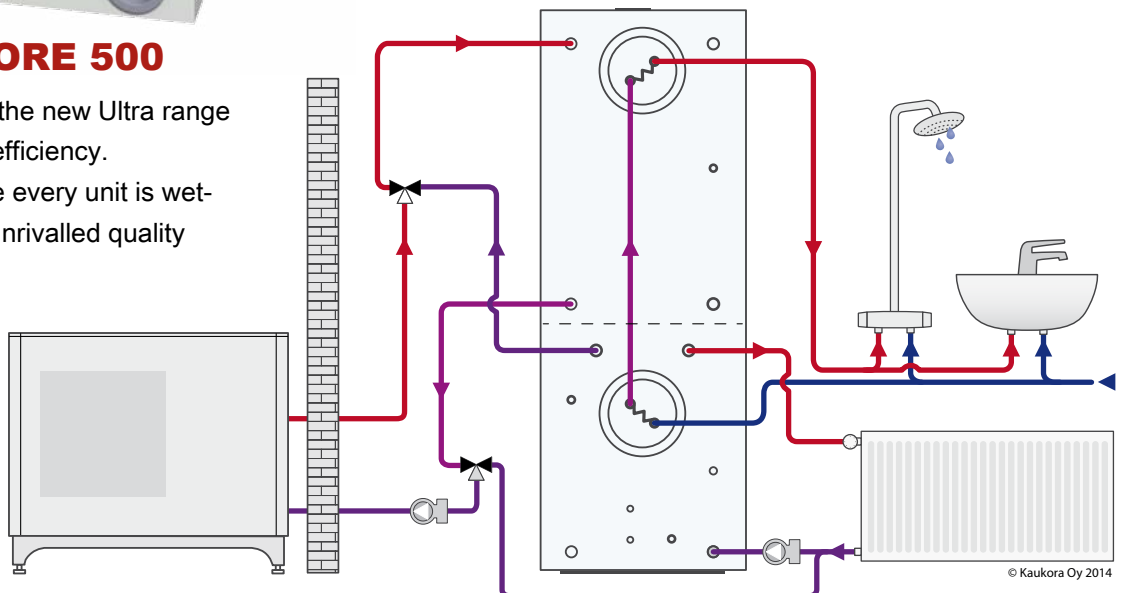

Ultrastore 500 with Heat Pump, Radiators and Domestic Hot Water

Specifications

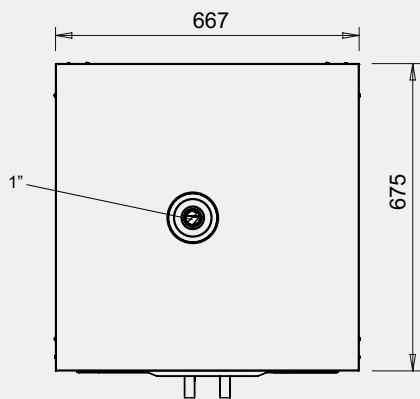
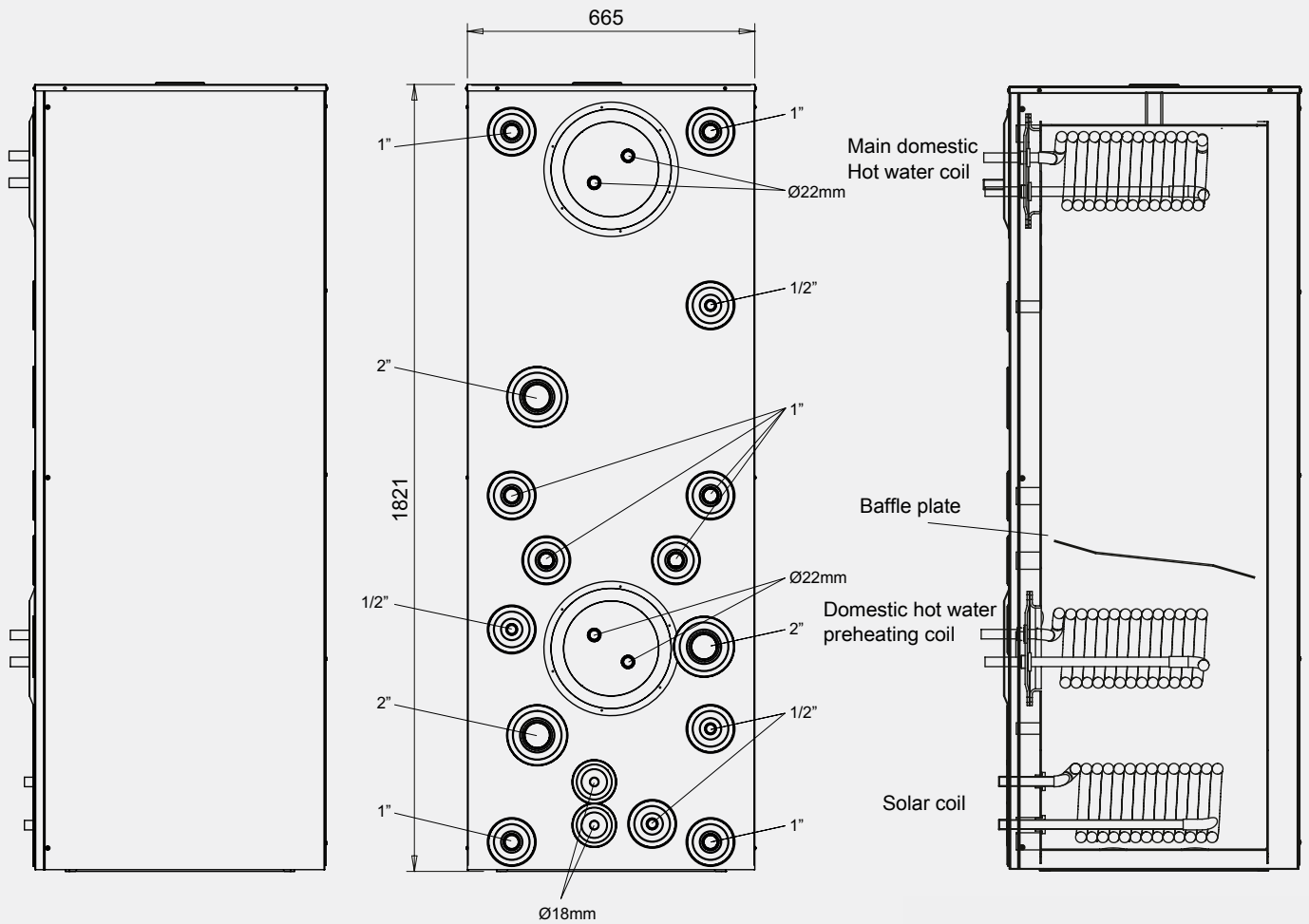

"Leak Detect" couplings points out installation problems quickly.



KAUKORA OY

JASPI UK
 info@jaspi.uk
 www.jaspi.uk
 01392 247 343

